



B9900BTPA

Fender Mounting Instructions for MIN1352 & MIN1354 Fenders

STEP 1

- A. Unpack all cartons and lay out parts.
- B. Compare the parts with hardware kit B9900BTPA as shown in Figure 1.

| PART NUMBER | DESCRIPTION | QTY |
|-------------------|--------------------------------|-----|
| PB5015 | 4.25" SWIVEL BRACKET | 6 |
| I62C450BFL8/RBZFT | 5/8-11 X 4 1/2 HEX FLANGE BOLT | 6 |
| I62CNCG/RBZ | 5/8-11 CLASS G FLANGE LOCK N | 6 |
| PB1/2"SPACER | 1/2" POLY SPACER | 18 |
| PB501026 | 26.5 COMPOSITE TAPERED BKT | 6 |
| PBLOCK | COMP BRACKET BACKING BLOCK | 6 |
| I31C300BSF/RBZ | 5/16- X 18 X 3 HEX WASH HEAD B | 24 |
| I31C100BSF/RBZ | 5/16-18 X 1 HEX WASHER HEAD BL | 36 |
| I31N150WFEZ | 5/16 X 1 1/2 FENDER WASHER | 36 |
| I31CNCF/RBZ | 5/16-18 CLASS G FLANGE LOCK | 60 |
| I31C100BSF/RBZ | 5/16-18 X 1 HEX WASHER HEAD BL | 8 |
| I31CNCF/RBZ | 5/16-18 CLASS F FLANGE LOCK | 8 |
| I31N150WFEZ | 5/16 X 1 1/2 FENDER WASHER | 16 |



Figure 1

STEP 2

- A. Lay the fenders out and clamp them together (Figure 2). This will make bolting them together much easier.
- B. An 8 pack of 1" bolts, 5/16" nuts, and 5/16" x 1 1/2" fender washers is included in the kit. Bolt the fenders together and tighten to the **Recommended torque is 10-15 ft-lbs.**



Figure 2

STEP 3

- A. Measure the suspension travel. This measurement is used to determine the distance between the fender and the wheel.
 - a. For air suspension systems, let the air out of the air bags.
 - b. For spring systems, measure from the stops on the springs to the bottom of the frame.

NOTE: For air suspensions with travel exceeding 6”:

In some cases a travel stop may need to be installed to prevent such large gaps between the fenders & tires. This will help with alignment and 5th wheel plate clearance. (Please call *Minimizer* @ 800-248-3855 for questions regarding this issue).

- B. Gap the fenders $\frac{3}{4}$ ” over the maximum travel point of the suspension system. The goal is to make sure the fender does not rub on the tire. A gap larger than $\frac{3}{4}$ ” may be necessary if using worn tires.

TIP: Establish the $\frac{3}{4}$ ” minimum gap required in Step 3B.

- a. For an air suspension system, place a $\frac{3}{4}$ ” board on top of the tires after the air has been let out of the airbags (Figure 3). Place the fender on top of the board.
- b. For a spring suspension system, add $\frac{3}{4}$ ” to the measurement from Step 3A.

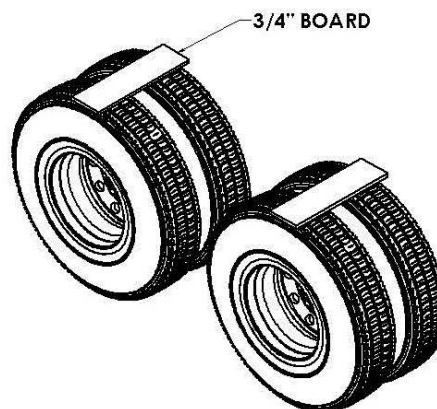

Figure 3

STEP 4

- A. Position the fenders exactly where they will be mounted.
 - c. Visually pick and mark the locations where the brackets will bolt to the frame.
- B. Try to use existing holes in the frame to bolt through. It is possible to remove any existing frame bolt and replace it with the supplied bolt in the bracket kit.

Tip: It is common for the front bracket to align with the existing quarter fender holes and the rear bracket to align with the holes left from the mud flap hanger.



Figure 4

NOTE: Depending on the length of the truck frame and the placement of the mud flap hangers, the fender may tuck inside the mud flap hanger. Figure 4 shows a truck with flaps and fenders.

NOTE: Do not drill into the weld or any other part of the light box. If a mud flap is mounted to the light box style fender and the mud flap is backed over, it may cause the interior welded plate to become loose. Slot the mud flaps to prevent this issue. This is NOT covered under warranty.



- C. Spacers are supplied to bring the steel swivel away from the frame in the event of any obstructions (Figure 5).
 - a. The ideal setup is to mount the steel swivel directly to the frame.

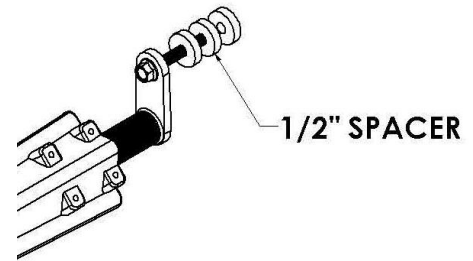

Figure 5

NOTE: Use spacers only when necessary.

- D. If possible, position the mounting brackets so they are located within 15" of the bottom of the fender. This protects against wind blowing the leading edge of the fender back into the tire (Figure 6).

Tip: If the front fender bracket is mounted higher than 15", refer to <http://www.minimizer.com/instructions.html> for further suggestions on adding additional support.

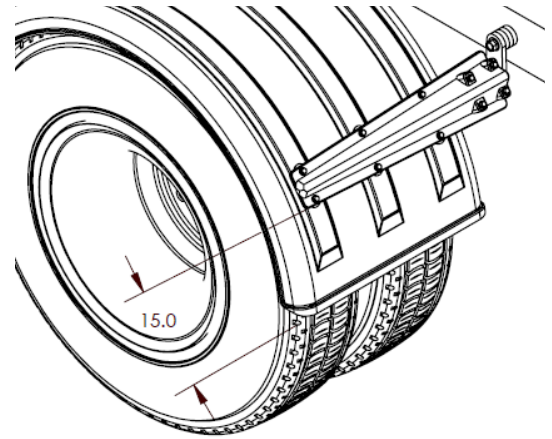

Figure 6

- E. Mount the center bracket so that it is directly over the seam where the fenders join together (Figure 7).

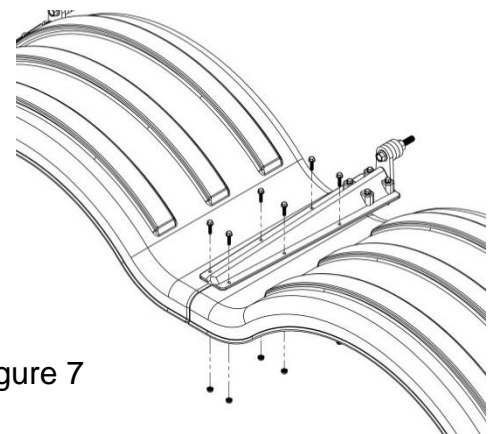

Figure 7

STEP 5

- A. Use four 5/16" x 3" bolts to attach the bracket (part number PB501026) and the backing block (part number PBLOCK) to the steel swivel (part number PB5015). Parts are labeled in Figure 8. The end of the pipe must be fully engaged into the bracket.

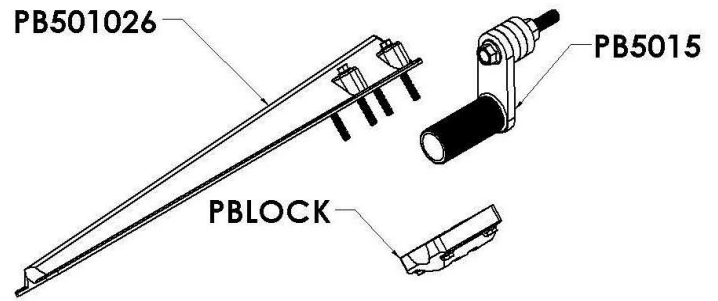

Figure 8

TIP: USE CARE WITH POWER TOOLS AS OVER-TORQUING WILL CAUSE CRACKS IN THE BRACKET. RECOMMENDED TORQUE IS 10-15 ft-lbs.

NOTE: DO NOT EXCEED RECOMMENDED TORQUE. THIS WILL VOID THE WARRANTY

TIP: Do not completely tighten one side of the backing block before moving to the other side. Alternate tightening bolts as pictured in Figure 9. Make sure to only tighten halfway and then repeat the pattern in Figure 9 until backing block is tight.

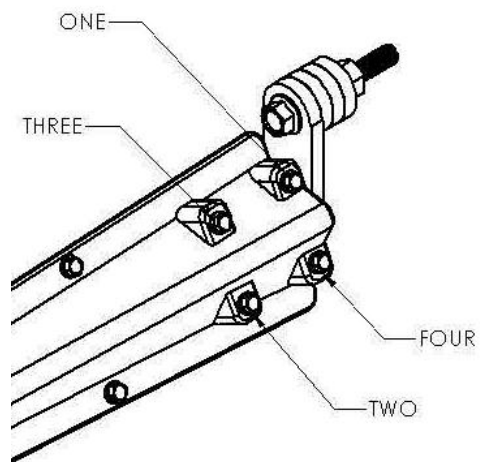

Figure 9

STEP 6

- A. Once the brackets are placed in position with the fender, securely tighten the 5/8" x 4-1/2" bolts that go through the PB5015 steel swivel to attach the swivel securely to the frame (Figure 10). **Recommended torque is 160-170 ft-lbs.**

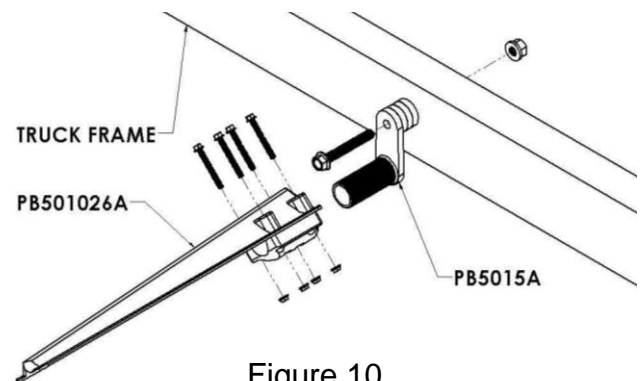

Figure 10

STEP 7

- A. Attach the bracket (PB501026A) to the fender.
- Drill six 5/16" holes through the fender using the holes in bracket PB501026A as a guide.
 - Install the 5/16" x 1" bolts through the bracket and into the fender.
 - Use six 5/16" fender washers and 5/16" nuts provided with the kit on the underside of the fender.
 - Tighten the bolts to recommended torque of 10-15 FT-LBS.** Hand tightening with Torque wrench is recommended. **DO NOT EXCEED RECOMMENDED TORQUE.**
 - Make sure the fenders are square and aligned (Figure 11). Twists or bows in the fender will fatigue the material over time.

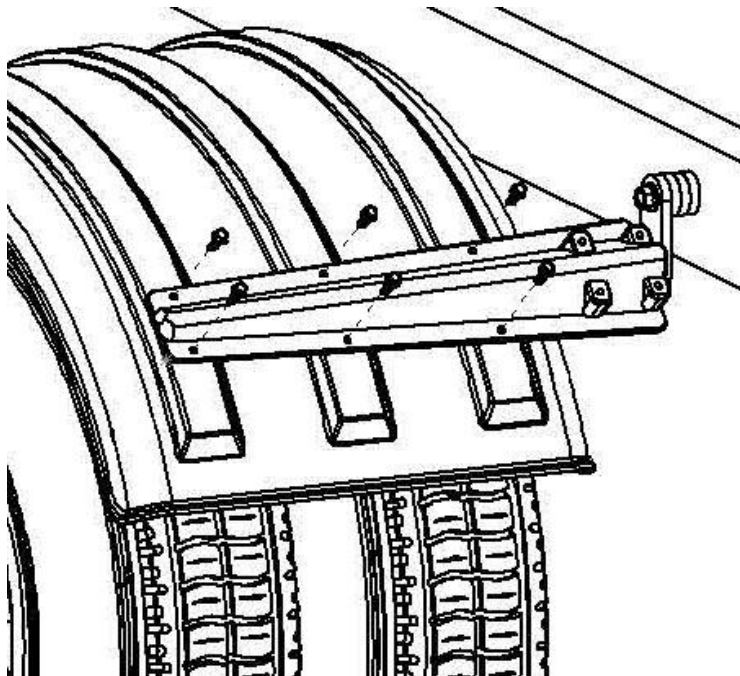

Figure 11

STEP 8

- A. For trucks with air suspension, raise and lower the suspension one final time to confirm that there is adequate clearance between the fenders and wheels.
- B. Recheck all brackets and bolts to ensure they are tightened to the recommended torque.

NOTE: ONCE FENDERS ARE IN SERVICE OCCASIONALLY CHECK TORQUE ON 5/8" X 4-1/2" HEX BOLTS IN THE FRAME TO MAKE SURE THEY DO NOT LOOSEN OVER TIME