

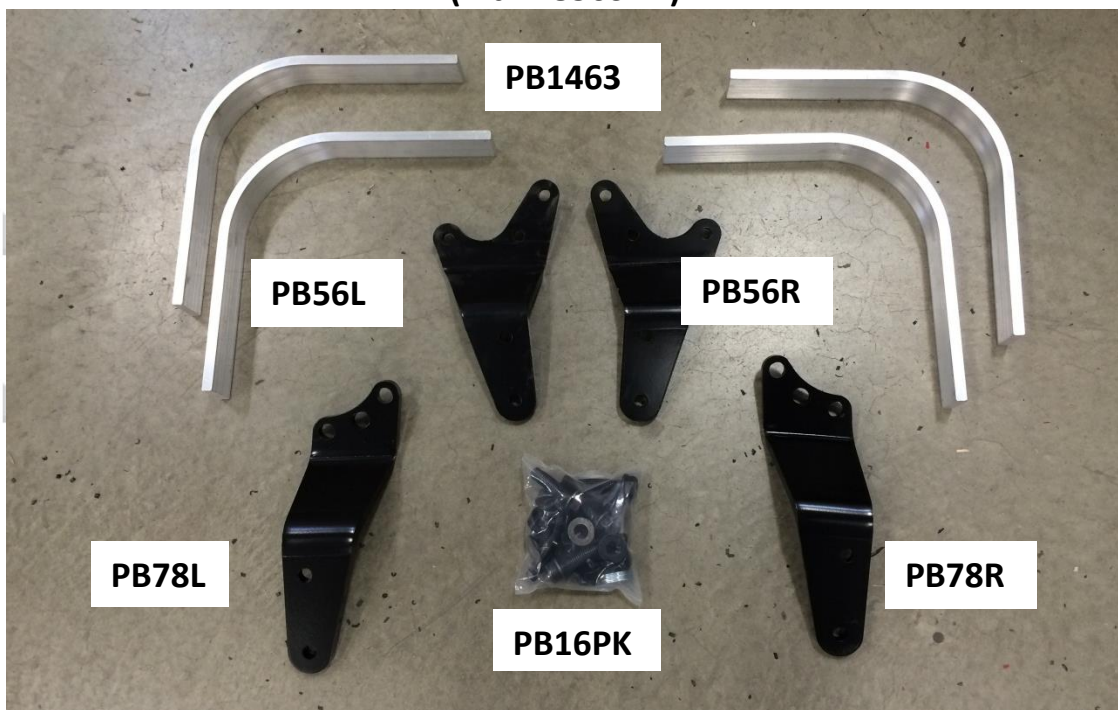

**INSTALLATION INSTRUCTIONS**  
**STEERABLE AXLE FENDER BRACKET KIT**  
**Four-Bolt Cam Flange Top Forward Mount**  
**(Kit# B856SBA)**



**\*\*BOLTS ARE ONLY PROVIDED FOR STEPS 9 & 10. BOLT SIZES VARY IN STEPS 1-8 DEPENDING ON THE APPLICATION AND ARE NOT PROVIDED.**

1. Remove the hub and drum assembly (with outboard hubs, you may only have to remove the drum).
2. Remove the lower three backing plate to spindle bolts on the rear side of the spindle.
3. Install the 016-22-78 mounting plate with longer grade 8 bolts and 2 to 4, SAE flat washers between the spindle and the offset mounting plate (This is to get the plate away from the irregular surface).
4. The other mounting plate 016-22-56 is to be bolted to the cam tube-mounting flange. Use both top bolt holes and one lower bolt hole with ½” longer bolts.
5. Install the hub and drums assembly.
6. Install wheels.
7. Cut the 12 ½” leg of the 10” (outside to outside) – or to desired length on all four aluminum arms.
8. Hold rear arms in place with 10” leg over tire 1-1/2” from tire tread to inside of arm. Trim other leg to fit onto bracket (on the inside, between bracket and truck frame).



9. Clamp in place with vise grip. (Make sure inside of arms point directly to center of spindle.) Mark & drill two 1/2" holes in each aluminum arms. Bolt each aluminum arm to the steel mounting brackets using 1/2" bolts with self-locking nut (provided in kit).
10. Install the fender on top of the aluminum arms. Roll fender until it is approximately the same distance from the end of the fender to the 2" arm on both ends of the fender. Make sure fender is parallel to tire. Drill 2 each 5/16" diameter holes on 6" centers (approximately 3" left and right of center) to bolt the fender to the arm. Use 5/16" bolts w/self-locking nuts (provided in kit).

### Recommended Placement of Brackets and Fenders for Correct Installation

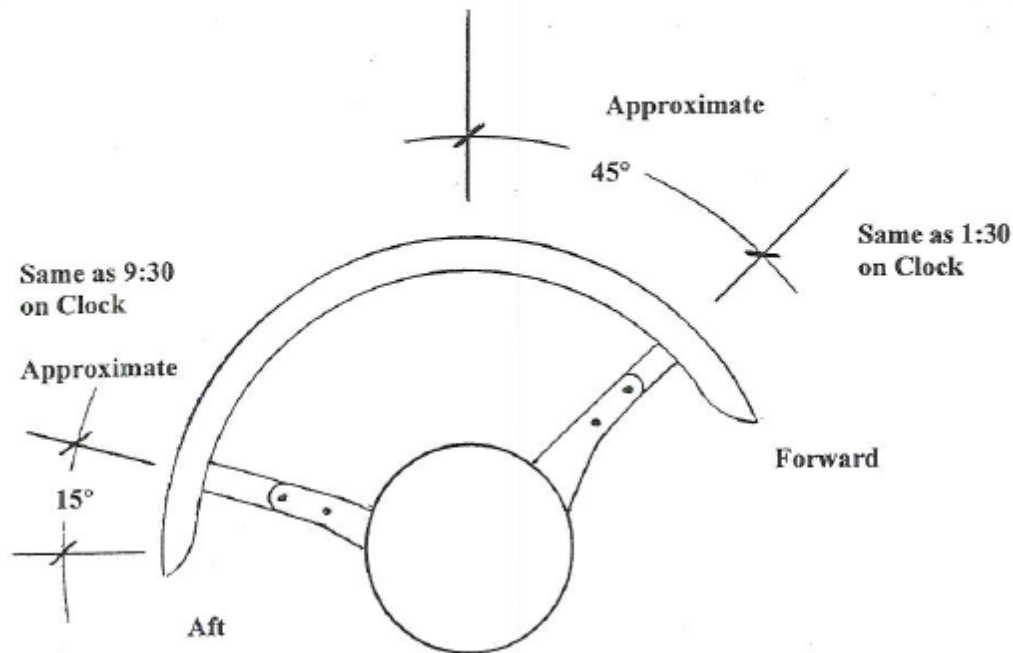

## Instructions for use of MIN221800 fenders with Minimizer steerable lift axle brackets:

- Inside the Minimizer bracket kit locate four steel plates (Minimizer part number 100447)
- The steel plates are to be installed on the exterior surface of the fender.
  - Align the steel plate so it is even (top to bottom) with the aluminum arm. Use one plate for each aluminum arm.
  - Drill two 21/64" holes through the fender using the steel plate as a template
  - Drill two 21/64" holes in the aluminum arm using the fender and steel plate as a template.
  - Use the 5/16-18"x 1-1/4" hardware provided by Minimizer to fasten the fender in between the aluminum arm and the steel plate.
  - **Tighten the 5/16-18X1-1/4 bolts to a recommended torque of 5-7 ft-lbs. Do not exceed the recommended torque.**
- Failure to install the exterior steel plates at the time of installation will void the manufacturer's warranty on the MIN221800 fender component.
- If installing fender model MIN161200 or any model other than MIN221800, the steel plates are not necessary and may be discarded.

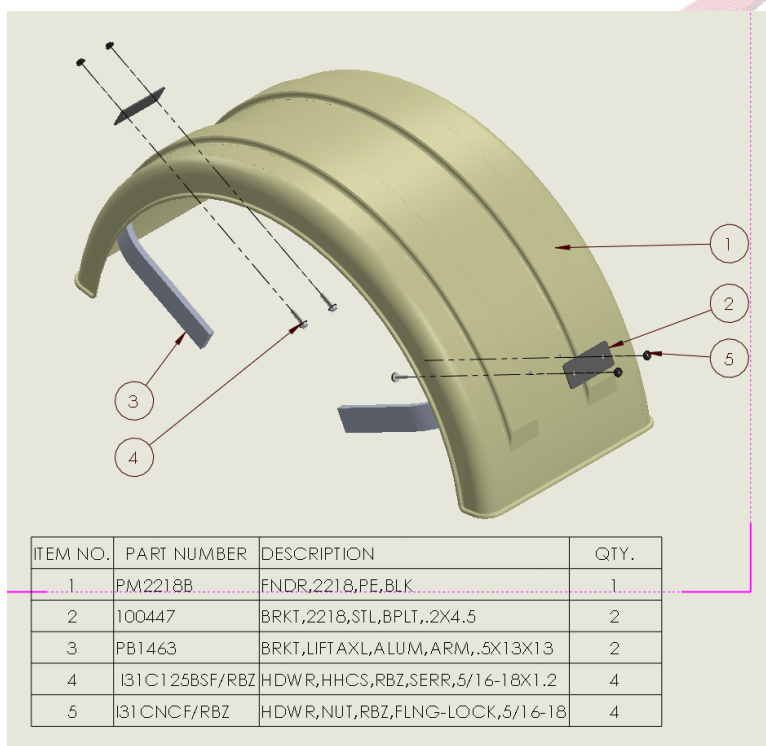

**Minimizer**  
the working man's fender

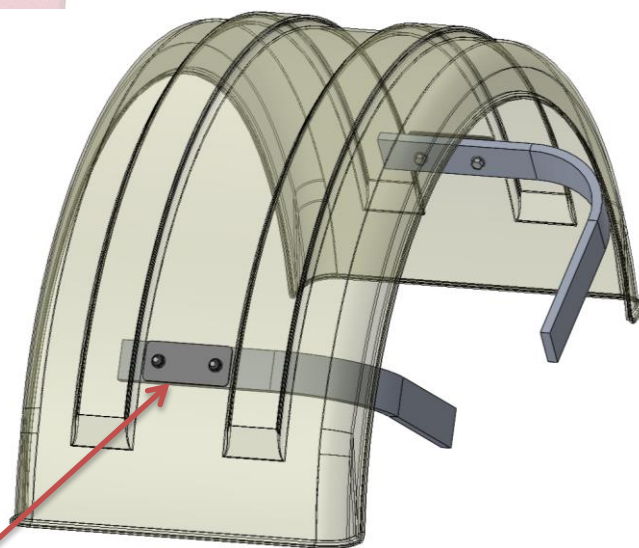

ALIGN STEEL PLATE WITH ALUM ARM

