

Installation Instructions for Steerable Lift Axle Fender Bracket Kit 10001445



Document #10005684, Revision A

Brackets are Compatible with Models:

Hendrickson HLUS-2, Fabricated Axle with Two Piece Spindle
& Eaton Four-Bolt Forward Cam Flange.

(Designed for use with MIN161200 & MIN221800)

STEP 1 - IDENTIFY PARTS

- A. Lay out parts and hardware packs.
- B. Compare the parts and hardware with bracket kit 10001445 as shown in **Figure 1**.

NOTE: Bolts are only provided for steps 3 & 4. Bolt sizes vary in step 2 depending on the application and are not provided.

FIGURE 1

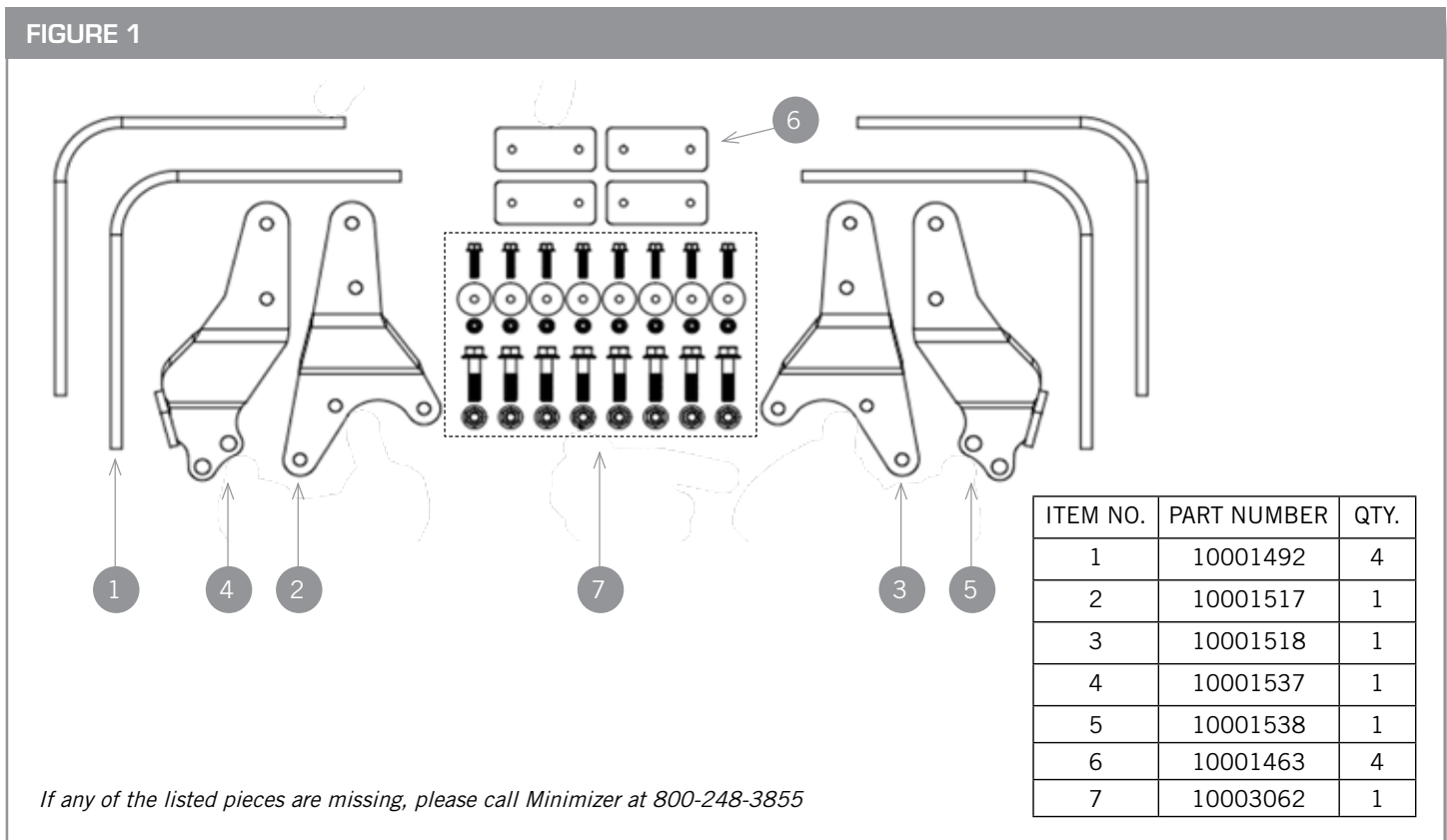

STEP 2 - ATTACH BRACKETS TO TRUCK

- A. Remove the wheel assembly from the hub on the right side of the vehicle.
- B. Remove the brake drum.
- C. Remove the lower two 5/8" bolts on the rear side of the spindle.
- D. Remove the 3/4" bolt in the steering arm that attaches the horizontal stabilizer.
- E. Install 5/8"x3" long grade 8 bolts in the lower two spindle holes with three 5/8" SAE flat washers on the top bolt and one on the lower bolt.
- F. Install three 3/4" SAE flat washers in the counter bore of the steering arm.
- G. Install the (10001538) rear bracket.
 - a. The flat washers should be between the spindle and the bracket.
 - b. The (10001538) fender bracket should be mounted inward, towards the frame.
- H. Re-install the horizontal stabilizer with a 3/4" x 5" grade 8 bolt.
 - a. The first stabilizer can be installed easily by shifting the tie rod to one side. To install the second stabilizer, the use of a small come along or ratchet strap to compress the first stabilizer makes the job much easier.
 - b. Tighten to the axle manufacturer's specifications.

- I. Install the (10001518) front fender bracket using both top holes and one lower hole of the cam tube mounting flange.
 - a. Use 1/2" longer bolts than the existing bolt size.
- J. Re-install the brake drum and wheel assembly.

NOTE:

- Repeat step 2 on the left side using fender brackets (10001537) and (10001517).

STEP 3 - POSITION BRACKETS AND FENDERS

- A. Place the Minimizer fender over the tire using shims for clearance. **(See Figure 2)**
 - a. Place a 1-1/2" block on top of the tire to establish a clearance between the tire and fender. **(See Figure 3)**
- B. Cut the four (10001492) aluminum arms to length depending on the application.
- C. Clamp the (10001492) aluminum arms parallel to the top edge of the steel fender brackets with vice grip clamps so the inside of the aluminum arm is 1-1/2" clear of the tire. **(See Figure 4)**
 - a. The aluminum arms may need to be adjusted inward or outward, so they make even contact with the fender.
 - b. If necessary, trim any excess material from aluminum arms that may extend past the bend in the mounting plate. **(See Figure 5)**

FIGURE 2



FIGURE 3



FIGURE 4

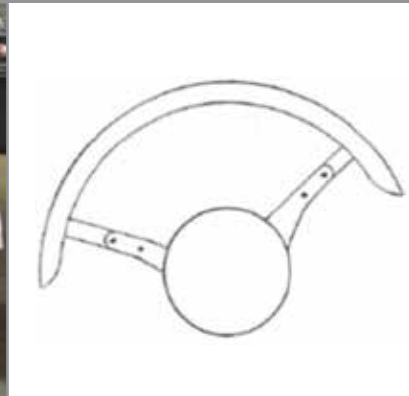
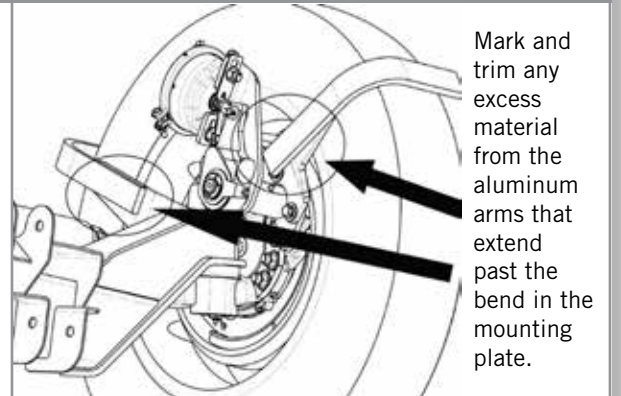

FIGURE 5



- D. Use the holes in the steel bracket attached to the axle as a template to locate and mark the mounting holes in the aluminum arms. **(See Figure 6)**
- E. Drill two 9/16" holes in each aluminum arm in the locations that were marked in the previous step.
- F. Bolt the aluminum arms to the steel fender brackets using the 1/2" x 2" flange head bolts and the 1/2" top lock flange nuts. **(See Figure 7)**
 - a. Recommended torque is 75-83 ft.-lbs.

FIGURE 6

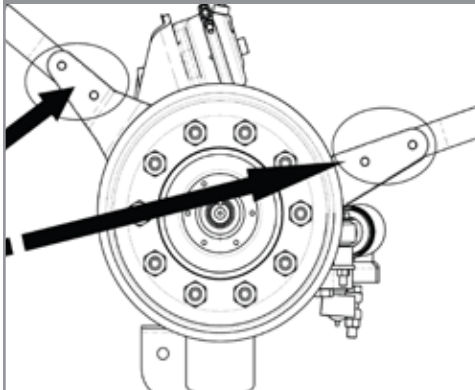
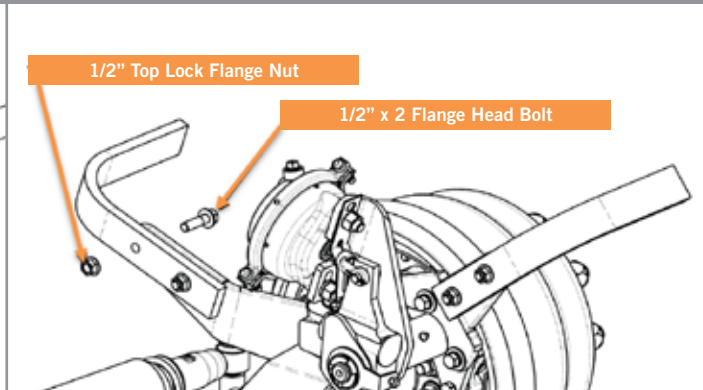

FIGURE 7



STEP 4 - ATTACH FENDER TO BRACKETS

- A. Attach the (10001492) aluminum arms and (10001463) steel backing plates to the fender. (See Figure 8)
- B. The (10001463) steel backing plates are not needed when installing the MIN161200 fenders and may be discarded.

NOTE:

- The (10001463) steel backing plate and the (10001492) aluminum arm **MUST** be installed on opposing faces of the fender to be eligible for Minimizer warranty.



- C. Confirm that the fender is parallel to the tire.
- D. Align the (10001463) steel backing plate so it is even (top to bottom) with the (10001492) aluminum arm. Use one plate per aluminum arm.
- E. Drill two clearance holes or tap threads in the aluminum arms.
 - a. Option 1 is to drill two 11/32" diameter holes thru the fender and aluminum arm using the steel backing plate as a template.
 - i. Use two 5/16"-18 bolts with self-locking nuts provided in the kit.
 - b. Option 2 is to drill and tap 5/16"-18 threads into the aluminum arm using the steel backing plate as a template. This option provides increased tire clearance.
 - c. Shorter 5/16" bolts are required for option 2 and are not included in the kit.
- F. Install fender bolts. **Recommended torque is 5-7 ft.-lbs.**
 - a. **DO NOT EXCEED THE RECOMMENDED TORQUE.**

STEP 5 - INSPECT AND REPEAT FOR ALL FENDERS

- A. Repeat steps 3 and 4 to install the fender on the opposite side of the vehicle.

A DIVISION OF **HIGH BAR BRANDS, LLC**



**HIGH BAR
BRANDS**



2701 18th Street SW, Owatonna, MN 55060
1-800-248-3855 | Fax: 507-583-7540
www.minimizer.com