

Installation Instructions for Steerable Lift Axle Fender Bracket Kit 10001458



Document #10003187, Revision A

Brackets are Compatible with Models:

Watson Chalin SL20K-2065 Axle Equipped with Bolt on Brake Cam Tube.

(Designed for use with MIN2220 Fenders.)

STEP 1 - IDENTIFY PARTS

- Lay out parts and hardware packs.
- Compare the parts and hardware with bracket kit 10001458 as shown in **Figure 1**.

FIGURE 1

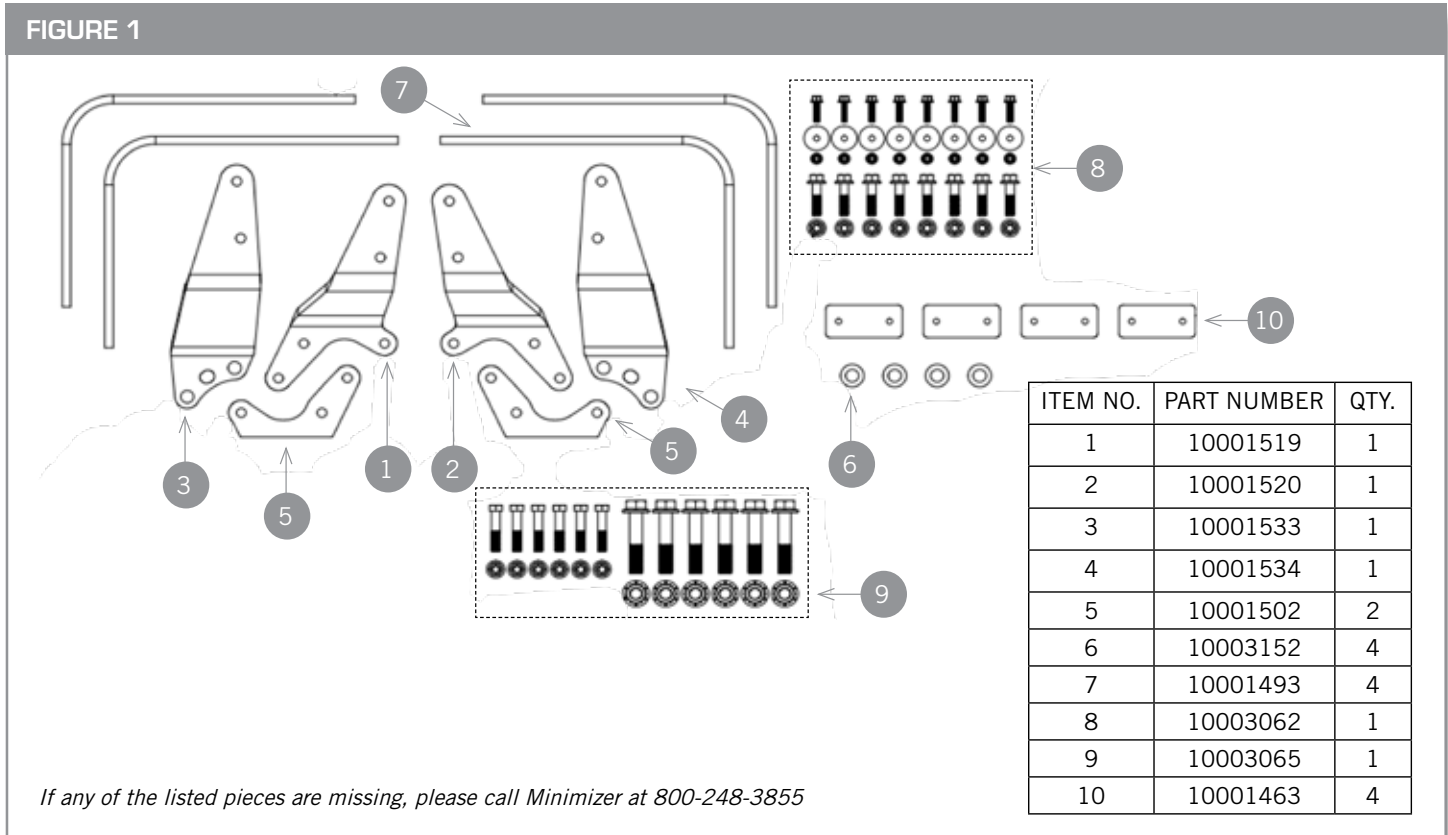

STEP 2 - ATTACH BRACKETS TO TRUCK

- Remove the wheel assembly from the hub on the left side of the vehicle.
- Remove the brake drum from the hub.
- Remove the metal dust shield (if equipped) that is attached to the inside of the spindle backbone assembly. (See **Figure 2**)

FIGURE 2



- D. Remove the brake return springs and brake shoes.
- E. Drain the oil bath and remove the wheel hub and bearings from the spindle to gain access to the mounting bolts as shown in **Figure 3**.
- F. At the front corner of the axle fit the (10001502) offset mounting plate and the (10001519) fender bracket around the brake cam tube.
 - a. Use the 1/2"-13 hex bolts and flange nuts provided in the kit.
 - b. **Recommended torque is 117 ft.-lbs.**

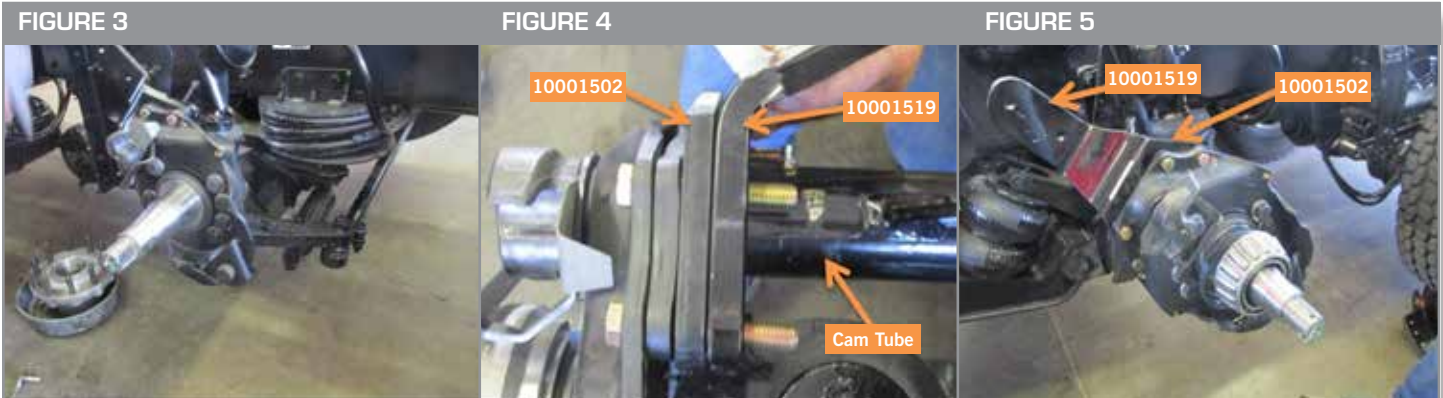

- G. Remove the lower three backing plate to spindle bolts on the rear side of the spindle. (**See Figure 6**)
- H. Install the (10001533) rear fender bracket using one (10003152) spacer each between the bracket and the spindle on the two bottom holes. The upper hole does not require a spacer. (**See Figure 7 and Figure 8**)
 - a. Use the 3/4"-16 bolts and locknuts that are provided in the kit.
 - b. **Recommended torque is 315 ft.-lbs.**

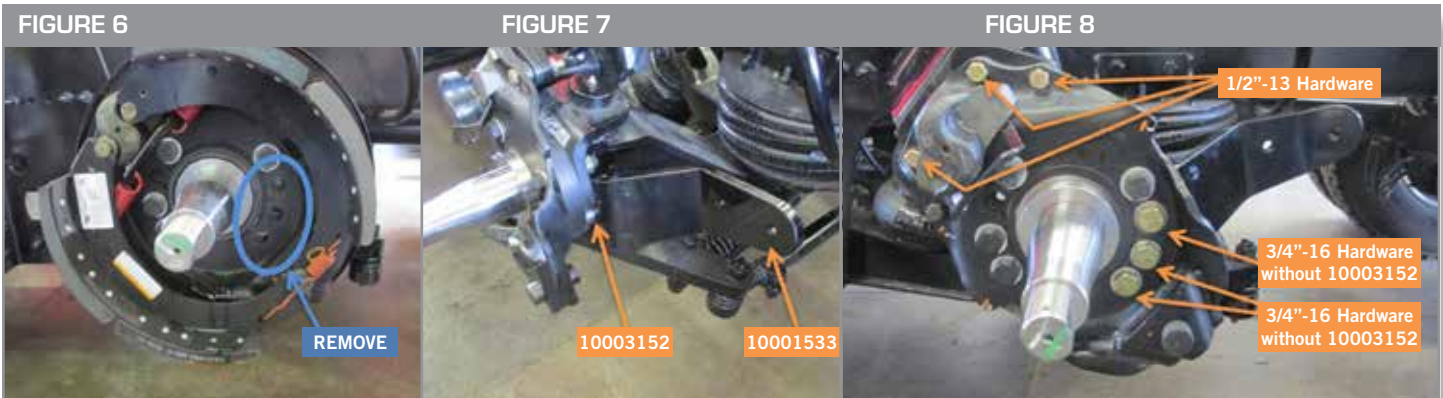

- I. Re-install the wheel hub, brake shoes, brake drum and wheel assembly. Make sure to torque all wheel lugs and wheel hub hardware according to the axle manufacturer's specifications.
- J. Verify that there is at least 1" of clearance between the steel brackets and the tire. For most applications with 445/25/R22.5 or 445/65/R22.5 tires, clearance should be approximately 2". (**See Figure 9**)



STEP 3 - POSITION BRACKETS AND FENDERS

- A. Place the Minimizer fender over the tire using shims for clearance. (See Figure 10)
 - a. Place a 1-1/2" block on top of the tire to establish a clearance between the tire and fender. (See Figure 11)

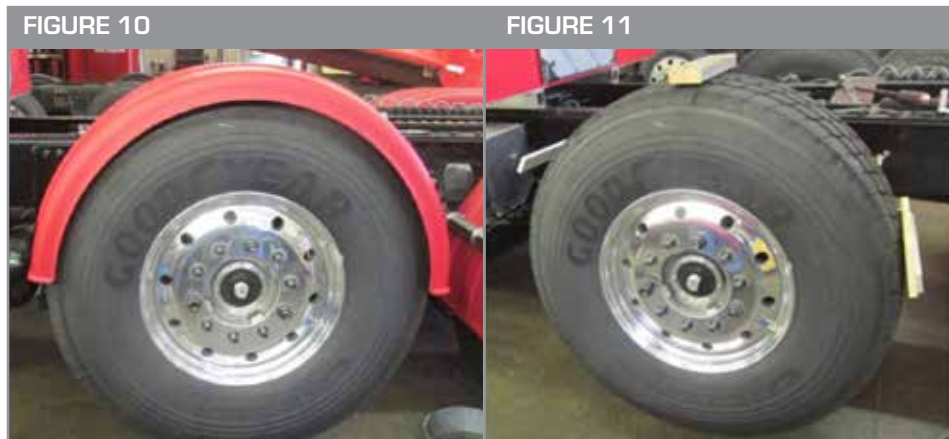

- B. Measure the distance from the floor to the bottom edge of the fender on both ends and adjust the position of the fender until both distances are equal.
 - a. The aluminum arms may need to be adjusted inward or outward, so they make even contact with the fender.
- C. Clamp the (10001493) aluminum arms to the fender brackets per the steps listed below:
 - a. Align the bottom edge of (10001493) aluminum arm flush with the bottom edge of the (10001519) fender bracket.
 - b. Place a 1-1/2" thick wood block in between the aluminum arm and the tire to establish the proper tire clearance.
 - c. Clamp the front aluminum arm to the surface of the (10001519) steel bracket closest to the truck frame with a vice grip clamp.
 - d. Make sure the clamp is tight enough to hold the wood block between the arm and the tire.
 - e. Align the top edge of the (10001493) aluminum arm flush with the top edge of bracket (10001533).
 - f. Place a 3/4" thick wood block in between the aluminum arm and the tire to establish the proper tire clearance.
 - g. Clamp the rear aluminum arm to the surface of the (10001533) steel bracket closest to the truck frame with a vice grip clamp.
 - h. For axle application with 425/65/R22.5 or 445/65/R22.5 tire, there should be at least 1-1/2" to 2" of clearance between the fender and the tire.
 - i. The bottom edge of the front aluminum arm will typically align 10-1/2" to 11-1/2" above the bottom edge of the fender.
 - ii. The bottom edge of the rear aluminum arm will typically align 1-1/2" to 2-1/2" above the bottom edge of the fender.
- D. Use the holes in the steel bracket attached to the axle as a template to locate and mark the mounting holes in the aluminum arms. (See Figure 12)
- E. Drill two 9/16" holes in each aluminum arm in the locations that were marked in the previous step.
- F. If necessary, measure and trim any excess material from the aluminum arms that extends past the bend in the mounting plate.
- G. Bolt the aluminum arms to the steel fender brackets using the 1/2" x 2" flange head bolts and the 1/2" top lock flange nuts. (See Figure 13)

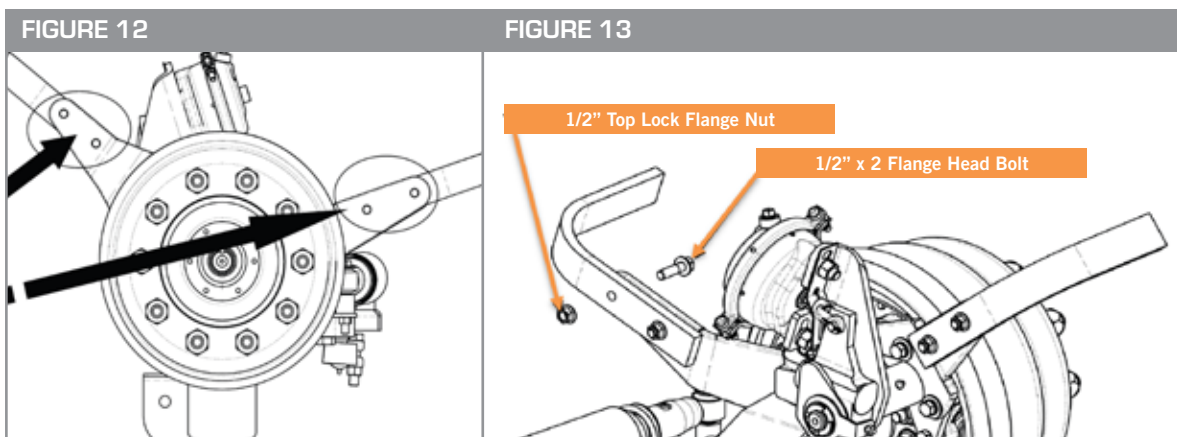

STEP 4 - ATTACH FENDER TO BRACKETS

- A. Attach the (10001493) aluminum arms and (10001463) steel backing plates to the fender. (See Figure 14)

NOTE:

- The (10001463) steel backing plate and the (10001493) aluminum arm **MUST** be installed on opposing faces of the fender to be eligible for Minimizer warranty.



- B. Confirm that the fender is parallel to the tire.
- C. Align the (10001463) steel backing plate so it is even (top to bottom) with the (10001493) aluminum arm. Use one plate per aluminum arm.
- D. Drill two clearance holes or tap threads in the aluminum arms.
- Option 1 is to drill two 11/32" diameter holes thru the fender and aluminum arm using the steel backing plate as a template.
 - Use two 5/16"-18 bolts with self-locking nuts provided in the kit.
 - Option 2 is to drill and tap 5/16"-18 threads into the aluminum arm using the steel backing plate as a template. This option provides increased tire clearance.
 - Shorter 5/16" bolts are required for option 2 and are not included in the kit.
- E. Install fender bolts and backing plates. **Recommended torque is 5-7 ft.-lbs.**
- DO NOT EXCEED THE RECOMMENDED TORQUE.**

STEP 5 - INSPECT AND REPEAT FOR ALL FENDERS

- A. Repeat steps 2 thru 4 to install the bracket and fender on the opposite side of the vehicle.

A DIVISION OF **HIGH BAR BRANDS, LLC**



2701 18th Street SW, Owatonna, MN 55060
1-800-248-3855 | Fax: 507-583-7540
www.highbarbrands.com